

JTW International, Inc.

AD60 SERIES FOAM SCRAP DENSIFIER



Reduce disposal costs and increase profits by converting your foam scrap into a manageable and recyclable product with the AD series foam scrap densifier / melter.

Features:

- Simple and quick to install and start up.
- Safe, quiet, clean and efficient operation.
- Minimal floor space required.
- Produces bricks that are easy to handle and stack. No baling wire required.
- Works with clean or dirty materials.
- Up to 90:1 densification. Permit up to 40,000 lb loads on 40' containers.
- Works with EPS, PE Foam, EPE and EPP

Reduce Costs & Increase Profits:

- Bin Rental, Haul off & Landfill Fees
- Floor Space Usage
- Housekeeping/Labor
- Sell Densified Scrap to Recyclers
- Increase Ship Weight per Truckload

Options:

- Auto shredder reverse
- Elevating stand
- Fume exhaust system
- Infeed conveyor



The AD60 series foam densifier is used to densify foam through a process of material shredding while adding heat to release air and gasses resulting in a "purge patty" which becomes a dense brick that is more efficient to transport or dispose of.

Bricks of pure material can be easily sold to recyclers, turning your scrap from a cost into a profitable product.



JTW shredders are designed and built for rugged operation. Tough materials such as EPE and EPP are easily processed through our dual shaft design. Heavy duty spherical bearings are standard, and the shafts are each driven by direct-coupled gearmotors.

Shredder Sizes:

- 21.5" x 19.5"
- 29.5" x 28"
- 49" x 28"



AD63 Single Outlet Densifier

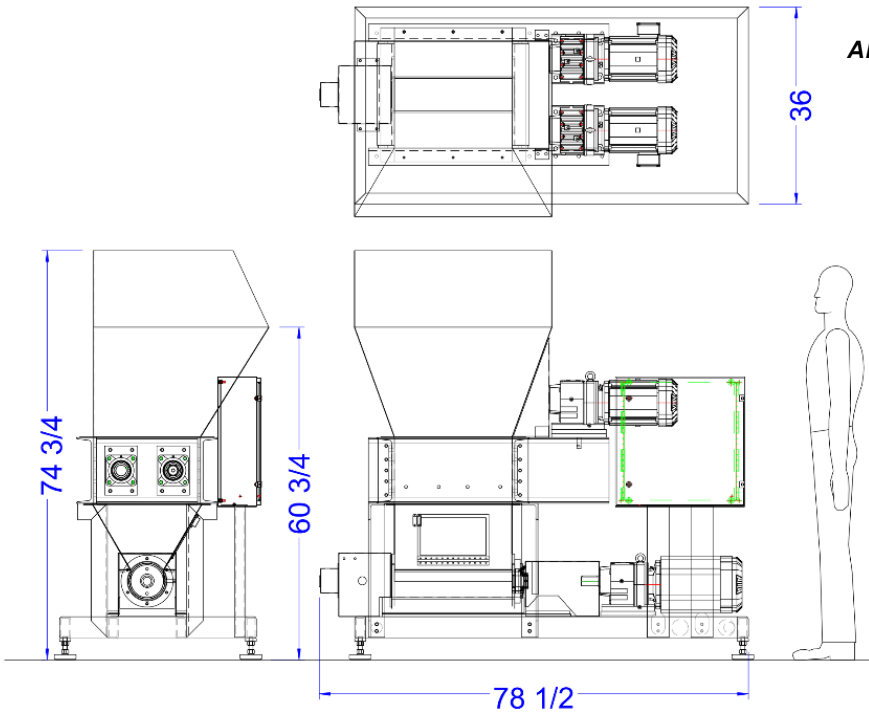

AD63 Densifier

Dimensions: 79"L x 36"W x 75"H
Capacity: Max 200 lb/hr*
Material Inlet: 19.5" x 21.5"

AD63-HD Densifier

Dimensions: 83"L x 48"W x 81"H
Capacity: Max 200 lb/hr*
Material Inlet: 29.5" x 28"

AD63-D Densifier

Dimensions: 83"L x 48"W x 81"H
Capacity: Max 400 lb/hr*
Material Inlet: 29.5" x 28"

MODELS:

* Depending on material and log density

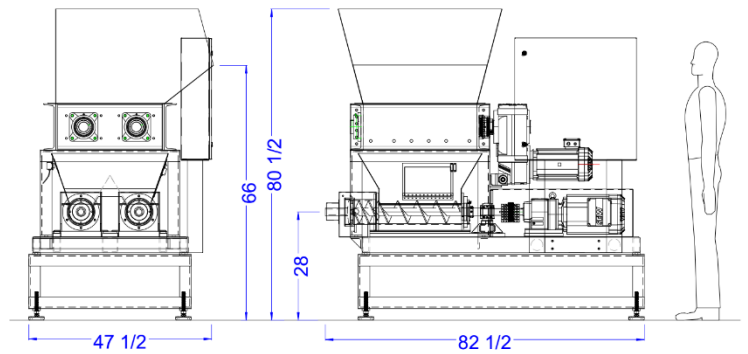
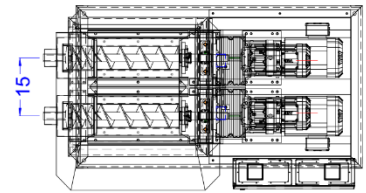

AD63D Dual Outlet Densifier

JTW International offers a variety of customized systems and solutions to meet your specific requirements, including remote shredders, air conveying systems, large volume hoppers, and Ethernet communication. Contact JTW to discuss how we can design a system to fit your needs.

JTW International, Inc.

312 Industrial Blvd.
Toccoa, GA 30577

www.jtwinternational.com
sales@jtwinternational.com



Made in USA